

Evoluto

Air Compressors

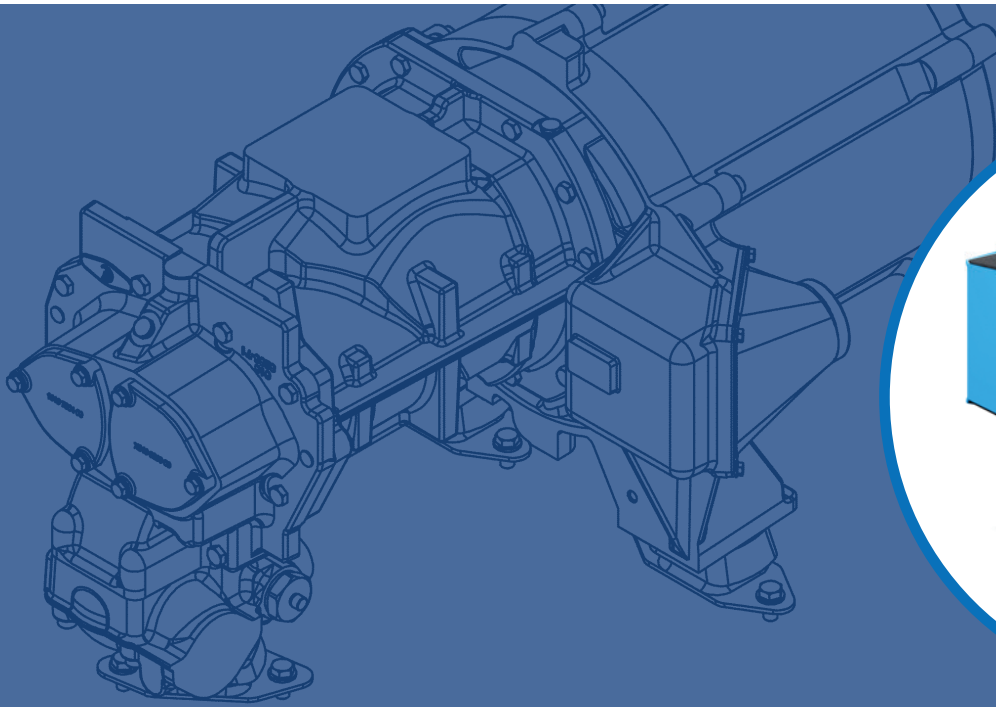

EVOLUTO 45-75

ALUP
Kompressoren

ALUP's heritage

Founded in Germany in 1923, the company derives its name of the automotive products that were manufactured in the Köngen' mechanical workshop where ALUP came into existence: Auto-LUft-Pumpen. Only two years later, the first range of piston compressors was being developed, whilst in 1980 rotary screw compressors were added to the product offer.

Over time, experience grew and innovation prospered, leading to today's high quality product portfolio. As such, the name ALUP Kompressoren has become synonymous with innovative technology blended with a strong sense of tradition.



Driven by technology Designed by experience

Discover what happens when a passion for technology is fused with hands-on industrial experience. Designs evolve towards more practical installation and maintenance, giving you the freedom to focus on your job. Product ranges include the exact machine you need, with the right options for your performance needs. Return on investment is ensured, while your carbon footprint shrinks. And, because we stay close to our customers, we're one step ahead when your needs change.

**INNOVATION
HANDS-ON
EXPERIENCE
PEACE OF MIND
TOTAL COST
OF OWNERSHIP
PARTNERSHIP**

Evolving energy efficiency

Continuous investment in product development has resulted in our most innovative and energy efficient compressor to date. A brand new and groundbreaking drive train coupled with our Imperium inverter has pushed energy efficiency to the next level, bringing energy savings of up to 45%. Designed with the customer in mind, the Evoluto 45-75 range brings:

Premium performance at minimal energy costs

- New generation in-house designed screw elements, delivering more compressed air for less energy.
- IE4 Super Premium Efficiency motor, resulting in significant energy savings.
- Integrated direct drive transmission for minimal losses.
- Imperium variable speed technology, bringing instant savings vs. traditional fixed speed compressors.

Our newest innovations in one package

- In-house designed interior permanent magnet (IPM) motor with innovative oil-cooling technology for optimal cooling at all conditions.
- In-house designed Imperium inverter, tailor-made for screw compressor applications.
- In-house designed graphical controller with touchscreen for user-friendly operation.

Reliable productivity

- Maintenance-free components enable higher uptime and increased productivity.
- Consumables with long lifetime ensure optimal reliability and low total cost of ownership.
- Packaged in a proven canopy design with already thousands of installations around the globe.



www.alup.com

10 reasons to choose Evoluto

The Evoluto range is the result of dedicated investments in R&D and in-house developed key components. By maximizing performance, energy efficiency and reliability of each individual component we have ensured that the final result is our most innovative compressor to date.

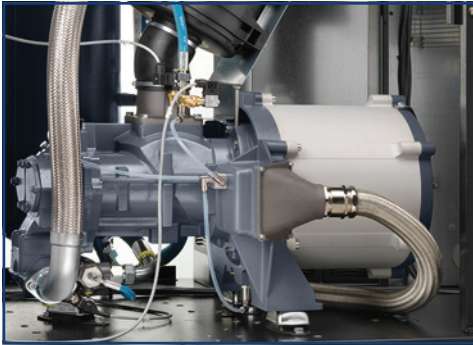

1. Interior Permanent Magnet (iPM) motor

- IE4 Super Premium Efficiency.
- Oil-cooled, optimal cooling at all speeds.
- IP66, highest possible protection against dust ingress.
- In-house designed.

2. New generation screw elements

- Superior performance and efficiency.
- Improved rotor profile, reduced pressure losses.
- In-house designed and produced in Belgium.

3. Integrated direct drive transmission

- Coupling-free design, minimal transmission losses.
- Maintenance-free for low total cost of ownership.

4. Smart inlet valve

- Optimizing the inlet flow to the screw element.
- Maintenance-free, low total cost of ownership.
- In-house designed.

5. Imperium - Variable Speed Technology

- Robust industrial design with IP5X protection.
- Tailor-made for screw compressor applications.
- In-house designed.

6. Airlogic² T touchscreen controller

- Easy-to-use full-colour graphical display with touchscreen.
- Integrated connectivity helps optimizing and save energy.
- In-house designed.





7. Solid inlet baffle with radial fan

- Small installation footprint, unit can be placed against a wall.
- Filters mats pre-filter incoming air, ensuring superior air quality.
- Highly efficient and low noise radial fan as standard.



8. Oil separator vessel

- Integrated minimum pressure valve (MPV) eliminates risk of leakage.
- Long lifetime thanks to cast iron parts.
- Designed for optimal oil separation and low oil carry over.

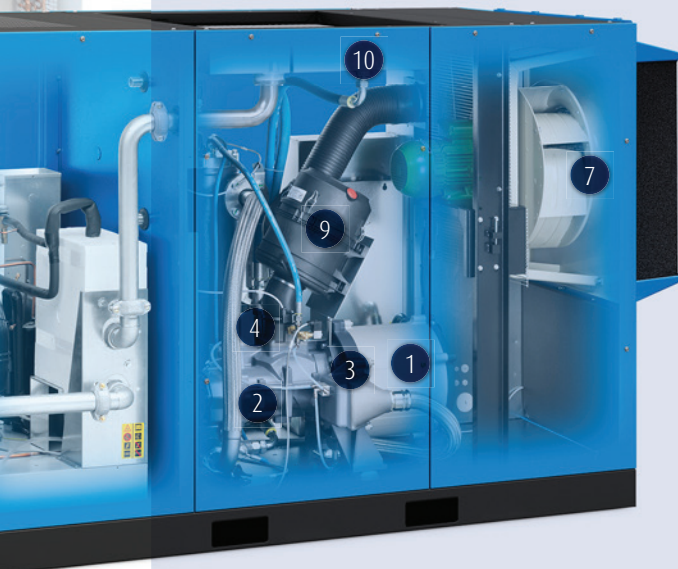

9. Quality filtration

- Protecting internal components and increasing lifetime.
- Heavy duty air/oil/oil separator filters with long lifetime for low total cost of ownership.

10. Separate coolers

- Separate oil and air cooler for high-quality cooling and long lifetime of the coolers.
- Gliding rails for easy and safe removal.
- Easy access for cleaning.



A big leap in energy efficiency

Why energy efficiency?

Energy costs represent about 70% of the total operating cost of your compressor over a 5-year period. Therefore reducing the energy consumption of your compressed air installation should be a major focus to ensure the lowest cost of ownership.

Why variable speed compressors?

As a majority of customers have a variable demand for compressed air, variable speed compressors are proven to be superior to fixed speed compressors when it comes to reducing the energy costs. By matching the air supply to the air demand, unload losses are avoided, and energy costs reduced on average by 30%.

Why invest in Evoluto?

In the Evoluto range we have combined our Imperium variable speed technology with our new and highly efficient drive train with iPM motor technology and evolved the energy efficiency of variable speed compressors to a new level, resulting in energy savings of up to 45%.

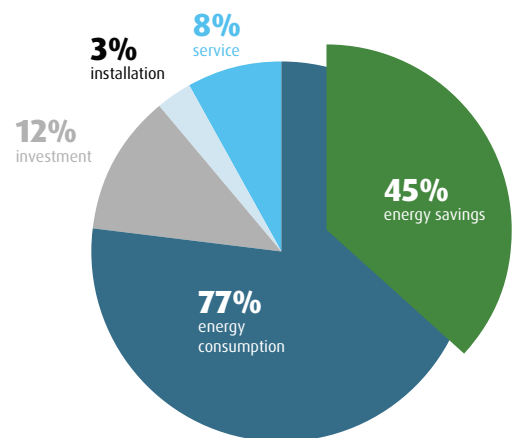
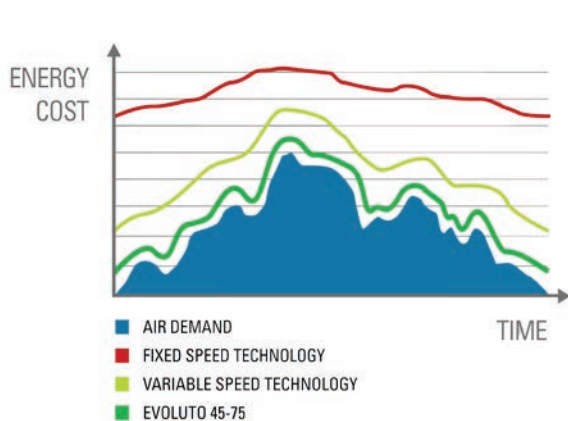

How much energy could you save in your existing compressor installation?

Contact us for an energy audit. We will measure the air demand and energy consumption of your existing installation and generate a detailed report at the end. Based on your specific situation we can simulate and show how much your energy costs would reduce with an Evoluto. If you would decide to invest in an Evoluto, you can expect a typical payback of 1-2 years.



Revolutionary drive train technology

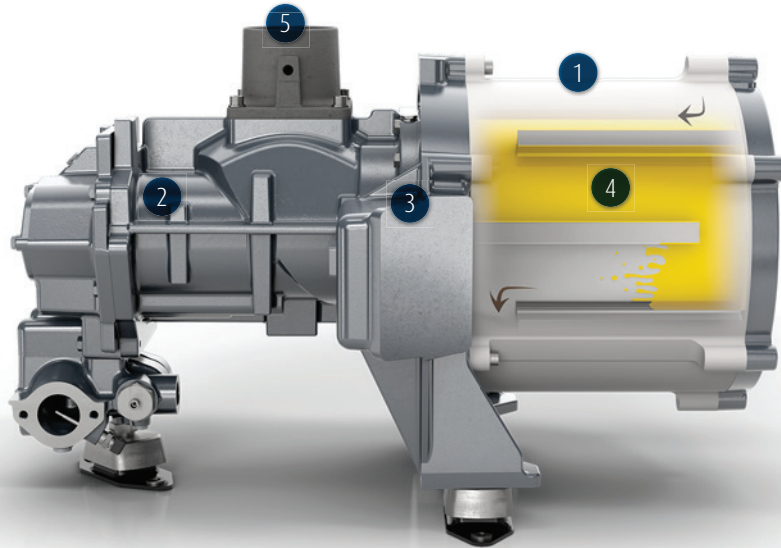

Improved energy efficiency saves you money

- In-house designed iPM motor (1) with IE4 Super Premium Efficiency
- New generation in-house designed screw elements (2), with improved efficiency
- Integrated direct drive transmission (3) for minimal losses.
- Smart inlet valve (5) optimizes the inlet flow and improves efficiency

Increased reliability extends lifetime

- iPM motor (1) rated IP66, premium protection against dust and water ingress
- Globally renowned screw elements (2), proven in thousands of installations.
- Optimal cooling at all speeds and conditions thanks to oil-cooling principle (4) of the iPM motor (1).

Maintenance-free design minimizes downtime and improves your productivity

- No (re)grease(ing) of the motor (1) bearing needed.
- Coupling-free direct drive design (3), no maintenance needed.
- Smart inlet valve (5), no maintenance needed.

75% of the heat recoverable via energy recovery

100% Total electrical energy consumption



Energy recovery

When air is compressed, heat is formed. The excess heat can be captured with an energy recovery option and channeled to other applications allowing you to save energy and cut costs. The energy recovery option integrates a heat exchanger on the oil circuit, which heats up the continuously pressurized water flow. The system is regulated automatically, and in case of limited water cooling capacity, the standard cooling system of the compressor will operate and backup the energy recovery device.

Airlogic² T touchscreen controller

The new Airlogic² T controller is truly state-of-the-art, maximizing user-friendliness, efficiency and reliability. With a large 4,3" full-colour touchscreen display and 30+ languages, smooth control is at your fingertips. The integrated connectivity with remote monitoring possibilities enables full insight into your compressed air network and helps you to optimize and save energy.

Control and monitoring features:

- Warning indications.
- Graphical indication service plan.
- Integrated ECO6i available as option to central control up to 6 compressors limiting the energy consumption and equalizing running hours across your whole system.
- Online visualization of running conditions.



Icons

Connectivity is the future. The Evoluto 45-75 comes fully prepared and enables you to benefit from all the advantages of ICONS:

- Remote monitoring that helps you optimize your compressed air system and save energy.
- On-time maintenance which optimizes costs and ensures a longer machine life.
- Potential problems are recognized before they can pose a threat to the continuity of your production.

Central controller technology

For installations with multiple compressors, a costly cascade system with a wide pressure band used to be the only way to operate. Additionally, the running hours of the compressors were not synchronized making strategic servicing difficult. Install the ECOntrol6 or the integrated compressor control (with a license) and get simple, central control to reduce system pressure and energy consumption in installations of up to 6 compressors.

Control features

- Single pressure measurement point.
- Minimized pressure band.
- Stable system pressure.
- Equalization of running hours.
- Multiple IVR speed control.
- Clear and visual graphical display.
- Online monitoring and controlling possible.



Upgrade Evoluto with built-in options

Air quality

- Internal water separator - reduces up to 90% of the condensate in the compressed air.
- Automatic drain - ensures no air loss during condensate removal (only in combination with internal water separator).
- Tropical thermostatic valve - for use in humid and hot conditions.
- High-efficiency air intake pre-filtration panel - avoids dust entering the compression element, protecting internal components and extending the compressor lifetime.
- Integrated refrigerant dryer - removes water condensate from the compressed air, minimizing the risk of product spoilage in your application.

Energy saving

- Integrated energy recovery - recovers up to 75% of the heat energy formed during the compression process, which can be used to heat up water for boilers, showers etc.
- ECO6i - integrated multiple compressor control for up to 6 compressors reduces system pressure and energy consumption.

Safety

- Water shut-off valve outside the canopy - for water-cooled machines.
- Oil pre-heater - guarantees a certain oil temperature in the oil vessel to avoid condensation.

Combine Evoluto with downstream auxiliaries

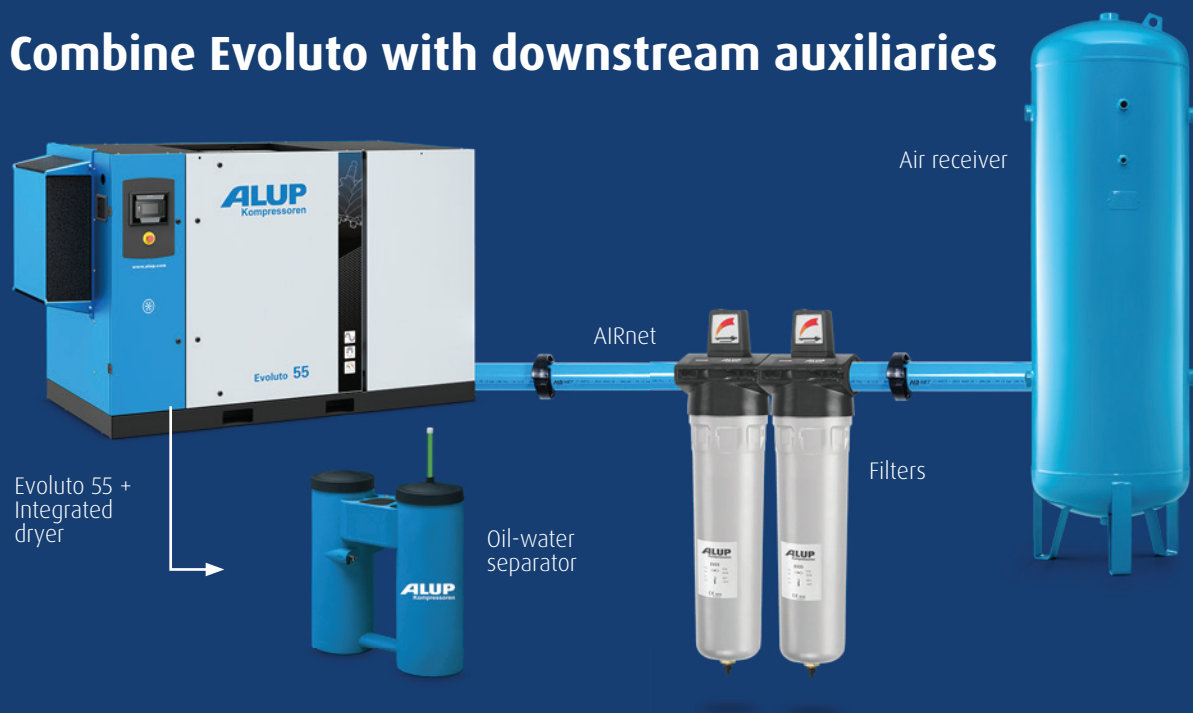

Line filters

Purify the compressed air by eliminating oil/dust contaminants resulting in higher final product quality and an increase of your overall productivity

Air receiver

Buffer storage for compressed air. Helps with condensate separation, pressure stabilization and more efficient operation of the compressor.

Oil water separator

Captures the oil in compressor condensate so it can be disposed of in a safe and environment-friendly way.

AIRnet

Fast to install, reliable piping system, designed for compressed air applications offers lowest total cost of ownership.

Enhanced air quality

Many people do not realize that the operating environment can have a major impact on the air quality at the compressor outlet. Even in a dedicated compressor room the inlet air can contain particulates or moisture which can have a negative impact on the production.

Evoluto 45-75 compressors come with an integrated dryer option, which offers significant advantages compared to a stand-alone dryer:

- Condensation removal at the source minimizing pipework corrosion.
- Reduced footprint, up to 1/3 of a stand-alone dryer.
- Intelligent dryer control, controlled by the Airlogic² T.
- Single service visit, reducing maintenance costs.
- No installation cost.



SCOPE XT

How do you get the most out of your compressor in the most cost-effective way? The simple answer is: SCOPE XT, the service plan that makes your life easy, keeps your compressor running energy-efficiently and avoids breakdowns. If you have just purchased a new machine, SCOPE XT provides an extending warranty up to 5 years. You do not have to worry about unexpected repair costs: it is all part of the plan!

Save energy



Original parts are replaced on time, ensuring optimal efficiency and reducing energy costs. for the whole period between service visits.

One order



Instead of ordering and paying for every individual spare part and service, one order is all you need.

Control budget



SCOPE XT offers full transparency, as the costs are fixed for the duration of the agreement.

Flexibility on top



You can decide how long you want the agreement to run and you can cancel with a notice of termination.

“SCOPE customers have on average two weeks of extra operation per year due to increased machine availability!”

Technical data

Inverter driven version	Working pressure	Min. Free air delivery (7 bar)*			Max. free air delivery								
		7	7	7	7	7	7	9.5	9.5	9.5	12.5	12.5	12.5
Model	bar	m ³ /h	l/s	cfm	m ³ /h	l/s	cfm	m ³ /h	l/s	cfm	m ³ /h	l/s	cfm
Evoluto 45	4-13	108	30	64	547	152	322	486	135	286	407	113	239
Evoluto 55	4-13	104	29	61	662	184	390	587	163	345	493	137	290
Evoluto 75	4-13	101	28	59	792	220	466	698	194	411	590	164	347

* Unit performance measured according to ISO 1217, Annex C, latest edition.

** Noise level measured according to ISO 2151 with optional baffle.

All technical data for air-cooled machines without integrated dryer. For technical data of water-cooled machines or machines with integrated dryer, please contact your local salesforce.

Model	Motor power		Noise level**	Cooling air volume	Weight		Compressed air output diameter
	kW	hp			std	plus	
			dB(A)	m ³ /h	kg		"
Evoluto 45	45	60	69	6660	860	1060	1 1/2
Evoluto 55	55	75	71	11160	880	1150	2"
Evoluto 75	75	100	71	11160	900	1170	2"



Dimensions

Model	Length std	Length plus	Width	Height
	mm	mm	mm	mm
Evoluto 45				
Evoluto 55	1923	2773	1060	1630
Evoluto 75				



DRIVEN BY TECHNOLOGY DESIGNED BY EXPERIENCE



**CONTACT YOUR LOCAL
ALUP KOMPRESSOREN REPRESENTATIVE**

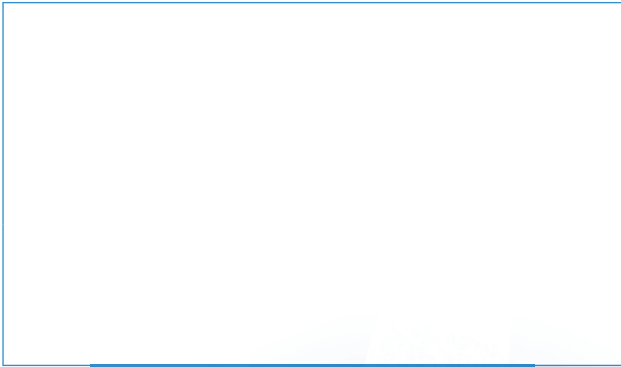

Care. Trust. Efficiency.

Care.

Care is what service is all about: professional service by knowledgeable people, using high-quality original parts.

Trust.

Trust is earned by delivering on our promises of reliable, uninterrupted performance and long equipment lifetime.

Efficiency.

Equipment efficiency is ensured by regular maintenance. Efficiency of the service organization is how Original Parts and Service make the difference.

6999640450